



---

# **ENTRY–EXIT TRANSMISSION PRICING WITH NOTIONAL HUBS**

## **CAN IT DELIVER A PAN-EUROPEAN WHOLESALE MARKET IN GAS?**

---

Paul Hunt<sup>1</sup>

February 2008

**NG 23**

---

<sup>1</sup> Paul Hunt is a Managing Consultant with IPA Economics. This paper has been drafted in a personal capacity and should not be taken to represent the views of IPA Economics.

The contents of this paper are the author's sole responsibility. They do not necessarily represent the views of the Oxford Institute for Energy Studies or any of its Members.

*Copyright © 2008*

***Oxford Institute for Energy Studies***

(Registered Charity, No. 286084)

This publication may be reproduced in part for educational or non-profit purposes without special permission from the copyright holder, provided acknowledgment of the source is made. No use of this publication may be made for resale or for any other commercial purpose whatsoever without prior permission in writing from the Oxford Institute for Energy Studies.

ISBN

978-1-901795-71-4

Dedicated to the memory of Ron Hopper whose enthusiastic efforts to advance a fully functioning European gas market and whose determination to overcome all obstacles were inspirational.

## **FOREWARD**

This paper has been a long time in the making. In late 2002, in the wake of the publication of the Brattle Group's paper recommending that Entry-Exit should become the approved gas transportation tariff methodology throughout Europe, Ron Hopper called me incandescent with rage. He believed that this methodology would fundamentally derail any attempts to create a liquid and competitive gas market in Europe to which the latter part of his career had been devoted. I immediately asked whether he would write a paper for the Gas Research Programme which I was then intending to create at Oxford. When Ron died in 2004, many of us lost not only a great friend, but also one of the greatest experts on European gas tariff design.

I was delighted when Paul Hunt agreed to look at Ron's outline for the paper and then to complete the task of writing it. This is not the paper that Ron would have written. As time passed, it became clear that – given its widespread adoption - there was little point in a paper which proposed a wholesale rejection of Entry-Exit tariff design. However, in pointing out the problems which this methodology creates and the limits which it imposes on any kind of pan-European gas trading regime, the paper retains much of the spirit – although perhaps not the colourful language – of Ron's original objections.

I am hugely grateful to Paul Hunt for seeing the paper through to publication. With all of his other commitments, this has taken somewhat longer than we had intended, but it remains highly relevant as the Commission moves towards implementation of the Third Package.

Jonathan Stern

March 2008

## CONTENTS

1. Introduction	1
2. What is Entry–Exit pricing?	2
2.1 Objectives	2
2.2 Methodology	2
2.2.1 <i>Transmission revenue recovery requirement</i>	2
2.2.2 <i>Analysis of peak-day flows</i>	2
2.2.3 <i>Estimation of long-run marginal costs</i>	3
2.2.4 <i>Deriving Entry and Exit tariffs</i>	4
2.2.5 <i>Scaling of tariffs</i>	5
3. The Attractions of Entry–Exit Pricing	6
3.1 Key features of EU transmission systems	6
3.1.1 <i>Construction in anticipation of demand</i>	6
3.1.2 <i>‘Meshed’ systems</i>	6
3.1.3 <i>Inter-system connections</i>	7
3.1.4 <i>External connections</i>	7
3.1.5 <i>Implications</i>	7
3.2 Entry–Exit capacity reservation	8
3.3 Entry–Exit transmission tariffs	8
4. Deficiencies of Entry–Exit Capacity Reservation and Pricing	10
4.1 Gas pipeline markets in North America	10
4.2 Problems with Entry–Exit	11
4.2.1 <i>Absence of clearly defined, tradeable transmission rights</i>	11
4.2.2 <i>Continued centralization of investment decisions</i>	12
4.2.3 <i>Complex and unnecessary generation of price signals</i>	12
4.3 Interim conclusion	12
5. Remedying the Deficiencies	14
5.1 Key features and implications	14
5.2 Redefining the interconnected EU transmission systems	15

5.2.1	<i>EU transmission systems' components</i>	15
5.3	Revised tariff derivation	18
5.3.1	<i>Recovery of fixed costs</i>	18
5.3.2	<i>Reflect the underlying system costs</i>	18
6.	A Possible Way Forward	19
Appendix A. Derivation of Entry–Exit Tariffs		21
Appendix B. Worked Example		24
	Entry–Exit data	25
	Transmission system facilities and values	26
	Transmission system cost base	27
	Unit Costs by pipeline segment	28
	Unit cost matrix	29
	Estimated and adjusted entry and exit tariffs	30
<b>Figures</b>		
Figure 1	Entry–Exit capacity and capacity to, and between, system hubs	17
Figure B.1	Simplified transmission system schematic	24
<b>Tables</b>		
Table B.1	System Entry–Exit data	25
Table B.2	Asset register	26
Table B.3	Annual transmission system revenue recovery requirement	27
Table B.4	Estimated unit cost by pipeline segment	28
Table B.5	Unit costs and revenues	29
Table B.6	Estimated system entry and exit tariffs and revenues	30
Table B.7	Adjusted entry and exit tariffs and revenues	30

# 1 INTRODUCTION

For almost 20 years since the Single European Act of 1987 the European Commission, in co-operation with the Council and Parliament, has been pursuing a programme to complete the internal market for electricity and gas. Much of the initial motivation sprang from concerns about the international competitiveness of European industries, but it has expanded to embrace a desire to provide competition and choice for all consumers and, more recently, to address concerns about security of supply in the context of a growing dependence on external suppliers of gas.

The process has been well documented and progress, by any objective criterion, has been patchy.<sup>2, 3</sup> Following the report of an inquiry by the Directorate-General for Competition (DG COMP) in early 2007 the Directorate-General for Transport and Energy (DG TREN) published its Third Legislative Package to accelerate progress.<sup>4</sup> This process is operating at the legislative, institutional, and organizational level. However, beneath and, to an extent, running parallel to this process, a separate process dealing with the pricing of gas transmission services is being rolled out throughout the European Union (EU). This is Entry–Exit pricing of gas transmission with notional hubs.

The purpose of this paper is to address the question ‘Can Entry–Exit transmission pricing deliver a pan-European wholesale market in gas?’ To answer this question it is necessary to address the following questions:

1. What is Entry–Exit transmission pricing?
2. What are its attractions?
3. What are its shortcomings and deficiencies?
4. How may they be overcome?
5. How may this be achieved?

---

<sup>2</sup> Directive concerning common rules for the internal market in electricity (96/92/EC) and Directive concerning common rules for the internal market in natural gas (98/30/EC), 22 June 1998.

<sup>3</sup> Directive concerning common rules for the internal market in electricity (2003/54/EC) and Directive concerning common rules for the internal market in natural gas (2003/55/EC), 26 June 2003. These are generally referred to as the Second Electricity and Gas Directives.

<sup>4</sup> Inquiry pursuant to Article 17 of Regulation (EC) 1/2003 into the European gas and electricity sectors (Final Report), COM (2006) 851 final, 10 Jan. 2007.

## **2 WHAT IS ENTRY–EXIT PRICING?**

### **2.1 Objectives**

Entry–Exit pricing of gas transmission capacity is designed to achieve two principal objectives:

1. To recover the annual costs of providing transmission capacity in a non-discriminatory, transparent, and objective manner from users of the transmission system.
2. To permit the separate booking (or reservation) and pricing of capacity at entry and exit points by users of the system.

### **2.2 Methodology**

The method is normally applied to a national transmission system with a well-defined number of entry and exit points.<sup>5</sup> The derivation of entry and exit transmission tariffs may be described precisely using matrix notation and such a description may be found in Appendix A. However, it is possible to capture the essential features of the tariff derivation by considering a national transmission system with 5 entry points and 20 exit points. These features may be described by examining the five principal tasks that are performed.<sup>6</sup>

#### **2.2.1 Transmission revenue recovery requirement**

In most EU Member States the annual revenue that a transmission business is allowed to recover for the provision of transmission services is determined by a national regulatory authority (NRA). A subsequent decision is made regarding the portion of this allowed revenue that may be recovered in Entry–Exit capacity tariffs.

#### **2.2.2 Analysis of peak-day flows**

The second task involves the analysis of gas flows on the system and this is typically performed on an annual basis in relation to the peak-day design flows. These flows will match exit (or off-take) requirements in the extreme demand conditions for which the system

---

<sup>5</sup> The identification of entry points is relatively straightforward as they comprise the outlets from producers' processing facilities, outlets from storage facilities, and the locations of gas transfer at national borders. The demarcation between the national transmission system and lower pressure delivery systems varies from country to country and this impacts on the number and location of exit points. As a result, as in the UK, exit points may be grouped into exit zones.

<sup>6</sup> This description is based on the procedure employed in Britain which was developed initially in 1992.

is designed. The use of peak-day design flows provides an appropriate measure of the total capacity available on the system.

If, for example, there are 5 entry points and 20 exit points, this will generate 100 (5 x 20) combinations of entry and exit points. However, gas will not normally flow from each entry point to each exit point. Gas flowing from one entry point will satisfy the full off-take requirements at a number of exit points and, normally, gas will not flow from the other entry points to these exit points. Beyond certain points on the system, gas from two or more entry points will combine to serve exit points further downstream.

### **2.2.3 Estimation of long-run marginal costs**

Once these peak-day design flows on the system have been established, the second task is to derive estimates of the costs of increasing gas flows from each entry point to each exit point in turn. Typically, the costs of delivering an increment of demand at each exit point from each entry point over a sustained period (for example, 10 years) are estimated. This increment of demand has to be sustained over and above the projection of the peak-day design flows on the system over the projection period.<sup>7</sup>

The objective is to generate a 5 x 20 matrix of costs for all combinations of entry and exit points. These cost estimates are considered an appropriate measure of the Long-Run Marginal Costs (LRMCs) for each combination. This requires time-consuming and comprehensive hydraulic and system-planning analyses. These analyses are rendered more complex by the fact that gas does not flow from all entry points to all exit points and the cost impact of delivery by displacement needs to be investigated for these combinations of entry and exit points.

This task may be made easier by employing a simplifying assumption about the LRMC estimates. If it is assumed that the LRMC from an exit point to an entry point is equal to the negative of the LRMC from the entry point to the exit point, it may be shown that the difference between the entries in any two rows will remain constant along the columns; and

---

<sup>7</sup> The resulting LRMC estimates may be sensitive to the size of the increment chosen.

the difference between the entries in any two columns will remain constant along the rows.<sup>8</sup> Applying this result means that it is possible to generate the 5 x 20 matrix of LRMCs by estimating the LRMCs from one entry point to each of the 20 exit points and the LRMCs from the four remaining entry points to one of the 20 exit points. The remaining 76 (= 100 – 20 – 4) LRMC estimates may be derived by difference.<sup>9</sup>

#### **2.2.4 Deriving entry and exit tariffs**

The fourth task is to derive 5 entry tariffs and 20 exit tariffs so that each combination is equal (or as close as possible) to the corresponding entry in the 5 x 20 matrix of LRMCs, which, for convenience, is labelled as **C**. Two options are available to derive the entry and exit tariffs.

*Option 1:* The first option employs the simplifying assumption described above. This permits the derivation of entry and exit tariffs that are equal to the LRMCs for each entry and exit combination. By setting the tariff at one entry point equal to an arbitrary value, it is possible to derive a set of exit tariffs. Since the difference between the entries in any two columns remain constant across the rows it is possible to derive the other entry tariffs.

In practice, negative entry or exit tariffs may emerge and this is entirely plausible; but the application of negative tariffs is problematic. In some cases it may be possible to adjust the arbitrary value chosen for the entry point to remove these negatives, but this option may not always present itself. In addition, the split between entry and exit tariffs is arbitrary and subject to change.

*Option 2:* The second option is more appropriate when a comprehensive analysis generates LRMC estimates for all combinations of entry and exit points. Typically, a least squares method is applied which attempts to minimize the sum of the squared errors between each combination of the entry and exit tariffs and the corresponding entry in **C**.

---

<sup>8</sup> The Brattle Group, “Convergence of Non-Discriminatory Tariff And Congestion Management Systems In The European Gas Sector”, September 2002. presents a rationale for this simplifying assumption and its implications.

<sup>9</sup> It is extremely unlikely that these 76 LRMC estimates derived by difference will match precisely the corresponding estimates derived from a full hydraulic and system-planning analysis. Differences will result from variations in the timing, sequencing and scale of investments in compression, reinforcement (looping) and new pipelines.

It appears to be accepted that no unique solution may be derived. To deal with this, either a particular value is imposed on the entry or exit tariff at a specific point or a constraint is imposed on the value that each combination of entry and exit tariffs may take. This approach generates an arbitrary split between entry and exit tariffs and it fails to achieve the best fit of the derived tariffs to the underlying cost data (in other words, it fails to minimize the sum of squared errors).

Appendix A demonstrates how a unique solution may be derived which eliminates these problems.

### **2.2.5 Scaling of tariffs**

The final task involves scaling these raw tariff estimates to ensure recovery of the portion of the total annual revenue requirement that is recovered in capacity tariffs.

### **3 THE ATTRACTIONS OF ENTRY–EXIT PRICING**

The process of gas market liberalization confronted the European Commission and policy-makers in the Member States with two challenges in relation to gas transmission. The first is the definition and allocation of transmission capacity – and the subsequent management of congestion (either contractual or both physical and contractual). The second is the challenge to develop and apply a transmission pricing mechanism that will reflect cost causation on the transmission network, will be compatible with an appropriate definition and allocation of transmission capacity, and will support the development of gas market liquidity.

Specific features of the development, configuration and operation of EU transmission systems enhanced the attractiveness of Entry–Exit capacity reservation and pricing.

#### ***3.1 Key features of EU transmission systems***

##### **3.1.1 Construction in anticipation of demand**

Most of the European transmission systems were built, in effect, on a ‘no (or minimal) risk’ basis. The integrated gas transmission and supply companies, by the grant of exclusive rights to supply and, in most cases, to transmit gas, had an almost absolute guarantee that consumers would ultimately pay for whatever investments they made. As a result, these companies were prepared to construct capacity in anticipation of demand.

##### **3.1.2 ‘Meshed’ systems**

Gas transmission systems in the EU have been developed almost entirely on a national or sub-national basis and this is reflected in the ownership of pipeline facilities within national borders. Within most of these national systems there is considerable pipeline interconnectivity and some system off-take (or exit) points may be supplied from several input (or entry) points at the same time or at different points in time. As a result, it is difficult to track gas flows between entry and exit points or to quantify in any precise or meaningful way the use of capacity between these points. These systems are frequently described as ‘meshed’ systems.

### **3.1.3 Inter-system connections**

The increasing reliance on external supplies means that increasing volumes of gas are entering at the EU border points and flowing through the national transmission systems containing these border points to adjoining national systems. Although there is considerable interconnectivity between the national (and sub-national) systems, the capacities of these interconnections are quantified at the internal border points rather than in terms of their ability to transmit gas between and through the connected national systems. Where such pipelines exist (for example, those that pass through the new Central and Eastern European Member States) they tend to be defined as ‘transit lines’ in an attempt to exclude them from the market liberalization process.

### **3.1.4 External connections**

The scale of the volumes delivered by pipeline (whether sub-sea or onshore) from the major external suppliers and the associated scale of the delivery infrastructure mean that there is limited interconnection of supply lines from different supply sources at the major EU border points.

### **3.1.5 Implications**

These features make it difficult to define firm, long-term transmission rights that may be priced and traded in a liquid secondary market and to establish gas trading hubs with sufficient interconnection, hub-support services, and liquidity at physical locations.

Entry–Exit pricing has proved attractive to the European Commission and policy-makers in a number of Member States because, at a superficial level, it provides a neat solution to these two challenges.

The significance of these two areas is attested by the issue of two Commission staff working papers<sup>10</sup> providing guidance on, and explanation of, the Gas Regulation<sup>11</sup> issued to enforce

---

<sup>10</sup> Commission staff working document on capacity allocation and congestion management for access to the natural gas transmission networks regulated under Article 5 of Regulation (EC) 1775/2005 (SEC)2007 822, 12 June 2007 and Commission staff working document on tariffs for access to natural gas transmission networks regulated under Article 3 of Regulation 1775/2005 (SEC)2007 535, 20 April 2007.

<sup>11</sup> Regulation (EC) 1775/2005 of the European Parliament and of the Council of 28 September 2005 on conditions for access to the natural gas transmission networks.

specific provisions of the Second Gas Directive. These may be described, respectively, as the Capacity Working Paper and Tariff Working Paper.

### **3.2 *Entry–Exit capacity reservation***

The Capacity Working Paper confirms the Commission’s long-standing preference for an Entry–Exit capacity allocation and reservation:

A capacity allocation mechanism based upon an Entry–Exit system where capacity at entry and exit points may be booked separately is considered to have a considerable advantage in the promotion of trade, liquidity and gas to gas competition, by limiting the disadvantage small shippers would have in a distance based tariff system. Entry–Exit regimes create the most flexibility for shippers, fostering efficient trade, market liquidity and secondary trading of capacity, by allowing shippers and new entrants to book capacity without specifying beforehand where this gas should go. They allow for the development of notional balancing points, where entry gas is brought to a virtual point in the system, from which point the same or other network users can transport to an exit point. The notional point can thus become a trading hub, and serve as a balancing point in network users' portfolios, as well as for the TSO<sup>12</sup> to source its balancing gas. Network users should therefore be able to book capacity for entry and exit points separately.<sup>13</sup>

---

<sup>12</sup> Transmission System Operator. It is possible to distinguish between ownership and operation of transmission networks – and, in some countries, this is the case – but, generally, in the EU the Transmission System Operator is treated as both owner and operator.

<sup>13</sup> Capacity Working Paper, page 7.

### 3.3 *Entry–Exit transmission tariffs*

The Tariff Working Paper confirms its equally long-standing preference for the associated transmission pricing mechanism:

An Entry–Exit system is generally regarded as most appropriate for ensuring a non-discriminatory tariff system, where the price of capacity at an entry or exit point is the same for all network users at that specific entry or exit point. The tariff for each entry and exit point must be objective and non-discriminatory.<sup>14</sup>

---

<sup>14</sup> Tariff Working Paper, page 2.

## 4 DEFICIENCIES OF ENTRY–EXIT CAPACITY RESERVATION AND PRICING

The deficiencies of Entry–Exit capacity reservations may be best described initially by examining a functioning competitive market in gas and pipelines.

### 4.1 *Gas pipeline markets in North America*

It is generally accepted that the North American gas market presents the most advanced and complete form of efficient and competitive markets in gas and pipelines.<sup>15</sup> It provides evidence in support of academic contentions about the effective functioning of markets and it provides a template against which the gas market reform process in Europe and elsewhere may be assessed. There is no doubt that the European Commission has been influenced by the experience in North America.

Despite the many institutional, regulatory, organizational, and administrative differences between the development of the gas industry in North America and that in Europe, the development of a liquid and competitive secondary market in transmission capacity is, perhaps, the most significant achievement. How it was achieved and its significance are described in a recent paper by Dr Jeff Makhholm.<sup>16</sup>

First, the [inter-state] gas pipeline industry involved traditionally regulated utilities under a single federal jurisdiction. Second, gas pipelines were unique in the nature of their sunk costs. Before the interstate gas transmission companies could finance their pipeline projects, they wrote implicit delivered gas contracts with gas distributors for essentially all interstate capacity in the country – contracts that could readily be transformed into firm transportation contracts. Those gas transmission contracts existed from the very

---

<sup>15</sup> The key institutional and organizational arrangements were developed initially in the USA and largely similar arrangements were implemented subsequently in Canada to provide the basis for the North American market that is being expanded geographically to incorporate Mexico.

<sup>16</sup> Jeff D Makhholm, 'Seeking Competition and Supply Security in Natural Gas: The US Experience and European Challenge', *NERA Economic Consulting*, 13 June 2007, page 38.

beginning because, regulation notwithstanding, capital markets required that gas distribution company buyers commit to a very long string of payments before the market would provide the capital to build the pipe. Third, the price of the gas shipped on these pipelines was by that time deregulated. Further, modern technology made it possible to track a shipper's gas through the network in real time. Fourth, electronic bulletin boards, mandated by the FERC [Federal Energy Regulatory Commission], provided comprehensive market information to buyers and sellers of capacity rights.

Given these features of the gas pipeline industry, the market could readily accept an efficient market in the rights to transmission services. Buyers held clear contractual rights to practically all existing interstate capacity. The FERC rate-making [or tariff-design] formula for pipelines was longstanding and well known. Re-selling pipeline capacity (on a temporary or permanent basis) was allowed on interstate pipelines. The market was well informed, with no particular information barriers. There were no artificial barriers to creation of new capacity.

## **4.2 *Problems with Entry–Exit***

The contrast with the USA (and North America) could not be more stark.

### **4.2.1 *Absence of clearly defined, tradable transmission rights***

The use of Entry–Exit hinders the quantification and definition of firm transmission capacity that may be allocated, assigned, or contracted for with precision. Two specific aspects of this hindrance may be identified:

1. The split between entry and exit capacity is arbitrary and changeable.
2. There is no direct correspondence between entry and exit capacity and the underlying transmission system.

As a result there is both limited ability and limited incentive to contract for such ill-defined capacity over any sustained period of time. This reduces any transfer value such capacity may have and hinders the emergence of a secondary market.

#### **4.2.2 Continued centralization of investment decisions**

A potentially more serious problem arises in relation to investment. A key feature of successful wholesale competition is the decentralization of investment decisions. The LRMC estimates on which Entry–Exit is based are the TSO’s view of the future investment requirements in response to incremental flows on every part of the system. This effectively implies a continuation of the centralized investment decision-making that characterized the industry prior to the unbundling of transmission and supply.

Not only is the emergence of a secondary market being hindered, but the potential signalling of investment requirements by a secondary market is being ignored. A primary market in transmission capacity provides a means of recovering the sunk costs of transmission capacity. A secondary market signals the value of using this transmission capacity. Entry–Exit pricing attempts to recover sunk costs and signal LRMCs. But this deters the long-term commitments that would recover sunk costs, maintains the centralization of investment decision-making, conveys distorted price signals, and prevents the emergence of more effective and relevant secondary market signals.

#### **4.2.3 Complex and unnecessary generation of price signals**

The calculation of LRMC estimates (and the resulting Entry–Exit tariffs) is both time- and resource-consuming and computationally complex. Transmission tariffs should aim to provide a means of recovering sunk costs and fixed operating expenditure in a reliable and predictable manner. No centralized tariff-design mechanism will generate price signals that ensure efficient use of capacity. Seeking to incorporate this feature is futile.

### **4.3 *Interim conclusion***

Entry–Exit transmission capacity reservation and pricing has been employed to compensate for the failure to develop well-defined primary and secondary transmission capacity markets in the EU. It is, by definition and in practice, incapable of doing so. In the absence of these market mechanisms it is not possible to develop an efficient and competitive internal market

in gas. The conclusion at this stage, in response to the principal question posed in this paper, is that Entry–Exit cannot deliver a pan-European wholesale market in gas.

## 5 REMEDYING THE DEFICIENCIES

The EU process of gas market liberalization will founder in the absence of a concerted effort to remedy these deficiencies. It is possible to confront this challenge, first, by recognizing the appropriate implications of some key features of the EU interconnected transmission systems and redefining the principal components and, secondly, by revising and improving the derivation of Entry–Exit tariffs.

### 5.1 *Key features and implications*

The highly interconnected and genuinely network nature of EU national (or sub-national) transmission systems means that it is not possible, in general, to define capacity between entry and exit points (and the use of this capacity) with any great degree of precision.

Entry points are defined not only at the external borders but also at the internal borders and this restricts the ability to identify long-line systems between supplies and markets.

The relative lack of supply-side pipeline interconnection and the existence of dominant suppliers when combined with the network nature of national transmission systems mean that there is limited potential to establish production and market centre hubs at defined physical locations. This, however, does not imply that there is no scope or potential for production hubs. Increased interconnection of pipelines at major EU entry points combined with a willingness of, or incentives to, major external suppliers to release volumes of gas for the purpose of trading would provide valuable additional trading and price information.

EU policy-makers, regulators, and TSOs have responded to these implications by promoting and developing Entry–Exit transmission pricing mechanisms for all transmission pipelines within national boundaries. These pricing mechanisms, in turn, permit the development of notional (or virtual) system hubs on the national (or sub-national) transmission systems where gas trading can take place.

The previous sections acknowledge the laudable intentions behind this approach, but they also highlight the problems it causes. Applying the approach to all transmission pipelines

within national boundaries prevents the definition of capacity between system hubs and hinders the emergence of viable physical trading hubs.

There is a minimum requirement to define and quantify transmission capacity into and between system hubs. This is necessary to provide an effective basis, initially for the primary market, and, then, for the secondary market. If, subsequently, it proves possible to define and quantify entry and exit capacity within system hubs, it will allow the coverage of the secondary market to expand, but it is not a necessary pre-condition.

This key modification will reduce the scope of Entry–Exit pricing and facilitate the emergence of efficient primary and secondary markets in transmission capacity.

## **5.2 *Redefining the interconnected EU transmission systems***

It is necessary to make a number of definitions in order to outline the proposed modification of the Entry–Exit approach.

### **5.2.1 EU transmission systems' components**

#### *5.2.1.1 Primary entry point (PEP)*

A primary entry point is:

1. An EU border point where pipeline gas is received from an external supplier.
2. The outlet of an LNG regasification facility.
3. The outlet of a processing plant supplied from indigenous reserves (either onshore or offshore).
4. The outlet of a storage facility (see definition of system entry points below).

#### *5.2.1.2 System eXit point (SXP)*

A system exit point is any point on the transmission system where gas is delivered to a lower pressure system or to a system-connected large volume consumer. System exit points may be grouped to form system exit zones.

#### *5.2.1.3 System entry point (SEP)*

A system (or a secondary) entry point is the location of the first system exit point (or junction for a lateral to the first system exit point) on the pipeline connecting the system either to a

primary entry point or to an adjoining transmission system. The outlet of a processing plant supplied from indigenous onshore reserves or the outlet of a storage facility may also constitute a system entry point if these facilities are embedded in the transmission system (i.e., if they are connected upstream or downstream of an existing system exit point).

#### *5.2.1.4 Primary entry capacity (PEC)*

Primary entry capacity is provided by the pipeline connecting a primary entry point to a system entry point.

#### *5.2.1.5 System entry capacity (SEC)*

System entry capacity is the capacity from the system entry point to the notional hub.

#### *5.2.1.6 System eXit capacity (SXC)*

System exit capacity is the capacity from the notional hub to a system exit point.

#### *5.2.1.7 Inter-system capacity (ISC)*

Inter-system capacity is provided by the pipeline connecting two distinct transmission systems. It will connect the last system exit point on the first system to the system entry point on the second system. Because many inter-system pipelines cross EU internal borders with different TSOs owning the portions to and from the border, it is necessary to define these two portions.

#### *5.2.1.8 Internal border point (IBP)*

An internal border point is the border crossing point between two interconnected transmission systems.

#### *5.2.1.9 System transfer capacity (STC)*

System transfer capacity is provided by the portion of an inter-system pipeline connecting the last system exit point and the internal border point.

#### *5.2.1.10 System access capacity (SAC)*

System access capacity is provided by the portion of an inter-system pipeline connecting the internal border point and the system entry point.

#### *5.2.1.11 Transmission system*

The transmission system (for the purposes of the modified Entry–Exit approach) is defined by the system entry and exit points. Primary entry pipelines and inter-hub pipelines, although

they may be owned, in whole or in part, by the TSOs which own and operate the transmission systems, are defined as separate entities. The principal reason is that capacity, and the use of capacity, on these pipelines may be quantified, contracted for, and traded on a secondary market rapidly and effectively.

These components are illustrated in the following figure.

**Figure 1. Entry–Exit capacity and capacity to, and between, system hubs**

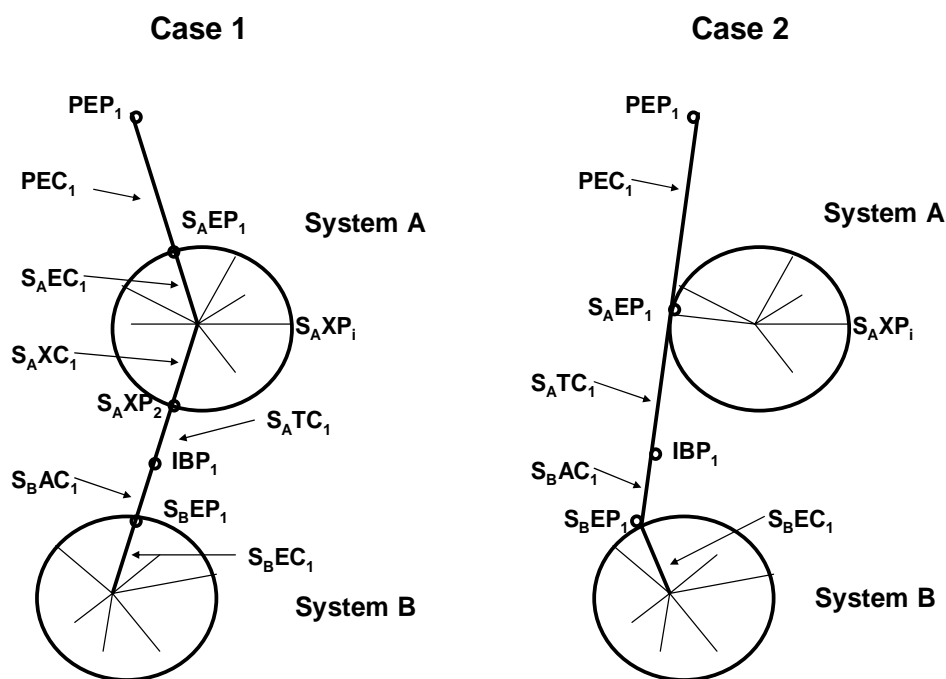

The primary objective of the definitions is to distinguish capacity to, and between, system hubs from entry and exit capacity within hubs. Figure 1 presents two cases. In Case 1 gas flows through System A to System B. The capacity from the Primary entry point (PEP<sub>1</sub>) to the notional hub in System B is comprised of the capacity segments PEP<sub>1</sub>, S<sub>A</sub>EC<sub>1</sub>, S<sub>A</sub>XC<sub>1</sub>, S<sub>A</sub>TC<sub>1</sub>, S<sub>B</sub>AC<sub>1</sub>, and S<sub>B</sub>EC<sub>1</sub>. Entry and exit capacity in System A is included.

In Case 2 some gas is delivered to System A at a single entry point before flowing on to System B and the capacity from the Primary entry point ( $PEP_1$ ) to the notional hub in System B is comprised of the capacity segments  $PEC_1$ ,  $S_{ATC_1}$ ,  $S_{BAC_1}$ , and  $S_{BEC_1}$ . No entry or exit capacity in System A is included.

### **5.3 *Revised tariff derivation***

Given that it is expected that Entry–Exit transmission pricing will be applied increasingly to national and sub-national systems it is possible to identify two important modifications that will improve the derivation of tariffs.

#### **5.3.1 Recovery of fixed costs**

The requirement on TSOs, when pricing transmission capacity in the primary market, is to recover the efficient costs of providing this capacity. This implies a focus on the recovery of the fixed (or sunk) costs of transmission capacity. This further implies that TSOs should not concern themselves with signalling the long-run or short-run marginal costs of using transmission capacity. If transmission capacity, and the associated contracts for this capacity, is sufficiently well-defined so that it can be traded in a secondary market, this market will signal both the short-run marginal costs of using this capacity and the requirement for investment far more efficiently and effectively than any TSO.

#### **5.3.2 Reflect the underlying system costs**

Even if the revised cost matrix presents the fixed costs of providing capacity on the peak-design day, it is not possible to derive entry and exit tariffs that will reflect precisely the costs for each combination of entry and exit points. The objective is to minimize the errors that, inevitably, will arise. The current method fails to do this and Appendix B presents a revised and more appropriate method.

## 6 A POSSIBLE WAY FORWARD

The implementation of the remedies proposed in the previous section will require concerted effort both at the technical level and at the institutional and regulatory level. The Third Legislative Package being advanced by the European Commission contains elements that may be developed to support the implementation, but this will need to be developed considerably. It is possible to outline some of the more important requirements:

1. Apply the definitions of the system components described in the previous section.
2. Confine the remit of national regulatory authorities to regulate the reduced-scope national (and sub-national) Entry–Exit systems.
3. Establish and empower European-wide regulation of primary entry and inter-hub transmission capacity.<sup>17</sup>
4. Apply a uniform method of asset valuation and accounting for the national and sub-national transmission systems.
5. Apply the revised Entry–Exit tariff mechanism to the reduced-scope national and sub-national systems. The NRA will be responsible for preparing a rolling multi-year capacity statement on an annual basis which will indicate the sizing and phasing of required investments. The NRA will authorize/licence new investments and these will be rolled into the asset base. The level and profile of transmission revenue will be determined for 4–5 year periods.
6. Define, quantify, and price primary entry and inter-hub capacity.
7. Devise and apply a mechanism to assign, allocate, or auction primary entry and inter-hub capacity on a long-term contractual basis and establish the basis for a secondary market in this capacity.
8. Enforce ‘interoperability’ with a single gas specification for the interconnected transmission systems. This will require centralized operation of the pipelines connecting national (and sub-national) systems and co-ordination of operation of these systems with these operators separated from system ownership. Shippers will be able to acquire

---

<sup>17</sup> The EU Commission’s proposal to establish an Agency for Co-operation of Energy Regulators (ACER) is a step in this direction, but its activities are envisaged to be limited to consultations and recommendations. It will not be equipped with the powers to make binding determinations.

capacity for any duration at any entry point or exit zone and to nominate receipt and delivery volumes within these reservations, subject to scheduling. Each national (or sub-national) operator would operate a within-day buy/sell mechanism to maintain system balance.

It is recognized that this amounts to a daunting challenge, but these constitute some of the key steps required to establish an effectively regulated primary market and an efficient and liquid secondary market in transmission capacity. In the absence of these market mechanisms the EU's gas market liberalization project is doomed to failure.

## APPENDIX A DERIVATION OF ENTRY–EXIT TARIFFS

For a transmission system with  $m$  entry points and  $n$  exit points the design peak use and configuration of the system is established as a base case. Estimates are made of the LRMCs of a sustained incremental input at each entry point being delivered to each exit point in turn. The cost impact is estimated even if gas does not flow directly from a specific entry point to an exit point. This generates an  $n \times m$  LRMC matrix,  $\mathbf{C}$ . The objective is to derive an  $n \times 1$  matrix of exit tariffs,  $\mathbf{X}$ , and an  $m \times 1$  matrix of entry tariffs,  $\mathbf{Y}$ , such that:

$$\mathbf{C} = \mathbf{X}\mathbf{M}' + \mathbf{N}\mathbf{Y}' + \mathbf{e} \quad (1)$$

$\mathbf{M}$  and  $\mathbf{N}$  are, respectively,  $m \times 1$  and  $n \times 1$  matrices of 1s and  $\mathbf{e}$  is a random error.

Applying a least squares method (with the usual assumptions about the distribution of the error term) defines the task as:

$$\text{Minimize} \quad \mathbf{e}\mathbf{e}' = (\mathbf{C} - (\mathbf{X}\mathbf{M}' + \mathbf{N}\mathbf{Y}'))^2 \quad (2)$$

Differentiating with respect to  $\mathbf{X}$  and  $\mathbf{Y}$  yields either:

$$\mathbf{X} = \mathbf{C}\mathbf{M}(\mathbf{M}'\mathbf{M})^{-1} \quad \text{and} \quad \mathbf{Y}' = 0 \quad (3)$$

or

$$\mathbf{Y}' = (\mathbf{N}'\mathbf{N})^{-1}\mathbf{N}'\mathbf{C} \quad \text{and} \quad \mathbf{X} = 0 \quad (4)$$

No unique solution is possible. Equations 3 and 4 present two extremes and there are an infinite number of solutions between these extremes. Equation 3 has zero entry tariffs with the exit tariffs expressed as the average value for each row in  $\mathbf{C}$ . Equation 4 reverses this result with zero exit tariffs and the entry tariffs expressed as the average value for each column in  $\mathbf{C}$ .

To resolve this indeterminacy, practitioners tend to impose a particular value on the entry or exit tariff at a specific point or to impose a constraint on the value that each combination of entry and exit tariffs may take. This allows a unique solution to be derived, but it cannot

ensure that the sum of squared errors is minimized. In addition, it imposes a specific, but arbitrary, split between entry and exit tariffs.

It is possible, however, to derive a split between the non-zero entry and exit tariffs defined in Equations 3 and 4 that minimizes the sum of squared errors.

These may be expressed as:

$$\mathbf{X} = \mathbf{CM}(\mathbf{M}'\mathbf{M})^{-1}\alpha \quad (5)$$

and

$$\mathbf{Y}' = (1-\alpha)(\mathbf{N}'\mathbf{N})^{-1}\mathbf{N}'\mathbf{C} \quad (6)$$

where  $\alpha$  is a scalar.

The minimization task becomes:

$$\text{minimize } \mathbf{ee}' = \left[ (\mathbf{C} - \mathbf{N}(\mathbf{N}'\mathbf{N})^{-1}\mathbf{N}'\mathbf{C}) - \alpha(\mathbf{CM}(\mathbf{M}'\mathbf{M})^{-1}\mathbf{M}' - \mathbf{N}(\mathbf{N}'\mathbf{N})^{-1}\mathbf{N}'\mathbf{C}) \right]^2 \quad (7)$$

Differentiating this expression with respect to  $\alpha$  yields a unique value for  $\alpha$  as follows:

$$\alpha = \frac{(\mathbf{M}'\mathbf{C}'\mathbf{CM}(\mathbf{M}'\mathbf{M})^{-1} - \mathbf{N}'\mathbf{C}\mathbf{M}(\mathbf{M}'\mathbf{M})^{-1}\mathbf{M}'\mathbf{C}'\mathbf{N}(\mathbf{N}'\mathbf{N})^{-1})}{(\mathbf{M}'\mathbf{C}'\mathbf{CM}(\mathbf{M}'\mathbf{M})^{-1} - 2\mathbf{N}'\mathbf{C}\mathbf{M}(\mathbf{M}'\mathbf{M})^{-1}\mathbf{M}'\mathbf{C}'\mathbf{N}(\mathbf{N}'\mathbf{N})^{-1} + \mathbf{N}'\mathbf{C}\mathbf{C}'\mathbf{N}(\mathbf{N}'\mathbf{N})^{-1})} \quad (8)$$

This daunting expression may be simplified as follows:

$$\mathbf{M}'\mathbf{C}'\mathbf{CM}(\mathbf{M}'\mathbf{M})^{-1} = \mathbf{m} \cdot \sum_{i=1}^n \left( \frac{\sum_{j=1}^m \mathbf{C}_{ij}}{\mathbf{m}} \right)^2$$

= No. of columns x Sum of squared row averages

$$\mathbf{N}'\mathbf{C}\mathbf{C}'\mathbf{N}(\mathbf{N}'\mathbf{N})^{-1} = \mathbf{n} \cdot \sum_{j=1}^m \left( \frac{\sum_{i=1}^n \mathbf{C}_{ij}}{\mathbf{n}} \right)^2$$

= No. of rows x Sum of squared column averages

$$\mathbf{N}'\mathbf{C}\mathbf{M}(\mathbf{M}'\mathbf{M})^{-1}\mathbf{M}'\mathbf{C}'\mathbf{N}(\mathbf{N}'\mathbf{N})^{-1} = \sum_{i=1}^n \left( \frac{\sum_{j=1}^m \mathbf{C}_{ij}}{\mathbf{m}} \right) \cdot \sum_{j=1}^m \left( \frac{\sum_{i=1}^n \mathbf{C}_{ij}}{\mathbf{n}} \right)$$

= Sum of row averages x Sum of column averages

The derived value of  $\alpha$  will minimize the sum of squared errors (and be positive) if the denominator of Equation 8 is positive.<sup>18</sup> The matrix of exit tariffs is simply  $\alpha$  times the average value of each row in  $\mathbf{C}$ ; and the matrix of entry tariffs is  $(1 - \alpha)$  times the average value of each column in  $\mathbf{C}$  (as in Equations 5 and 6).

---

<sup>18</sup> Alternatively, it is possible to use the Solver tool in Microsoft Excel to derive the value for  $\alpha$ .

## APPENDIX B WORKED EXAMPLE

The proposed modifications may be best described by means of a simple worked example. Figure B.1 presents the schematic of a simplified transmission system.

**Figure B.1. Simplified transmission system schematic**

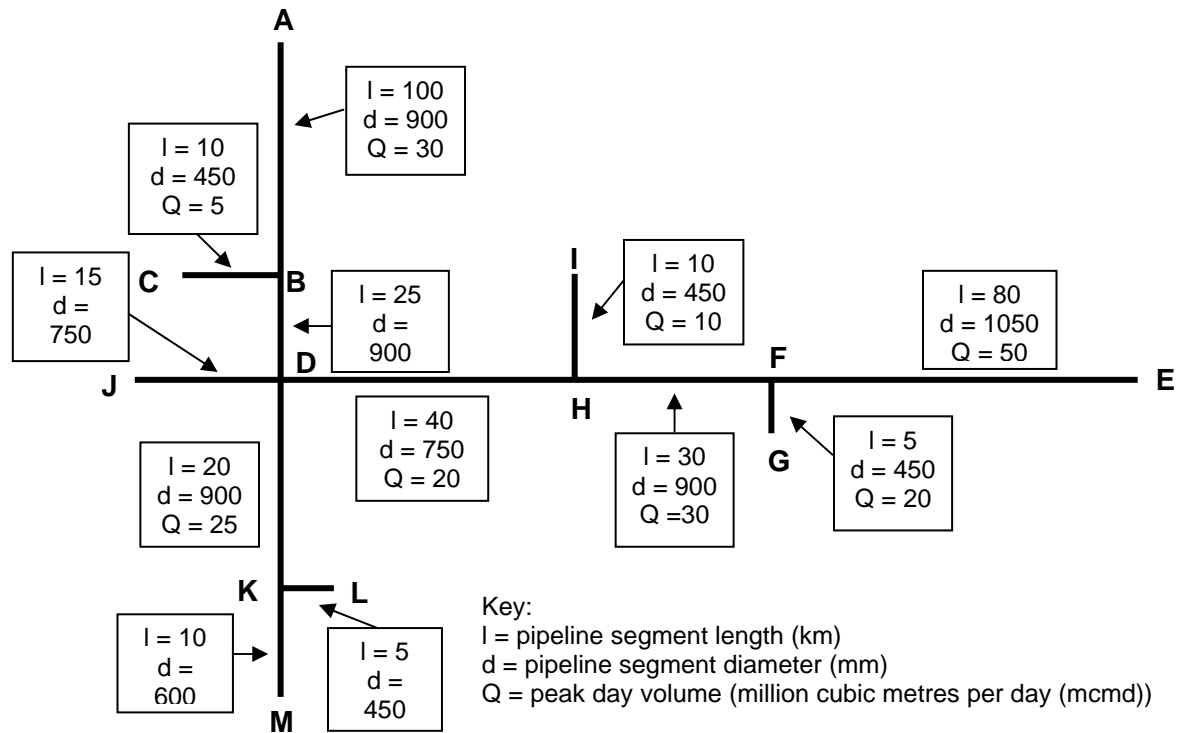

### 6.1.1 Entry–Exit data

In line with the definitions, segments AB and EF are primary entry pipelines. The extent of the transmission system is defined by the system entry points A and E and by the system exit points C, G, I, J, L, and M. Capacity utilization on the system is derived in terms of the system design peak-day flows. Entry and exit volumes are presented in Table B.1.

**Table B.1. System Entry–Exit data**

<b>Demand</b>	<b>Capacity (mcmd)</b>
Off-taker at C	5.0
Off-taker at G	20.0
Off-taker at I	10.0
Off-taker at J	20.0
Off-taker at L	10.0
Off-taker at M	15.0
Total	80.0
<b>Supply</b>	
Input at A	30.0
Input at E	50.0

## 6.1.2 Transmission system facilities and values

The basic asset register is presented in Table B.2.

**Table B.2. Asset register**

<b>Pipeline segment</b>	<b>Diameter (mm)</b>	<b>Length (km)</b>	<b>Peak day flow (mcmd)</b>	<b>Year commissioned</b>	<b>Current cost replacement value (million Euro)</b>
AB	900	100	30.0	1991	72.49
BC	450	10	5.0	1991	3.62
BD	900	25	25.0	1992	18.07
EF	1050	80	50.0	1998	81.32
FG	450	5	20.0	1998	2.18
FH	900	30	30.0	1999	26.16
HI	450	10	10.0	1999	4.36
HD	750	40	20.0	2001	29.18
DJ	750	15	20.0	1992	9.03
DK	900	20	25.0	1994	15.19
KL	450	5	10.0	1994	1.90
KM	600	10	15.0	1996	5.64
<b>Total</b>					<b>269.14</b>

The current cost replacement value is employed to reflect an economic valuation of the assets.

### 6.1.3 Transmission system cost base

It is assumed that:

1. All pipeline assets are depreciated on a straight-line basis over 40 years.
2. The pre-tax (real) Weighted Average Cost of Capital is 6.11%.
3. Operating & Maintenance (O&M) Expenditure is equal to 4% of the gross asset value.

Applying these parameters to the asset register generates the annual revenue recovery requirement.

**Table B.3. Annual transmission system revenue recovery requirement (million Euro)**

<b>Pipeline segment</b>	<b>Net asset value</b>	<b>Depreciation</b>	<b>Return on Net Assets (RONA)</b>	<b>Annual capital charge</b>	<b>O&amp;M</b>	<b>Total</b>
AB	43.49	1.85	2.71	4.56	2.96	7.51
BC	2.17	0.09	0.14	0.23	0.15	0.38
BD	11.29	0.46	0.70	1.16	0.74	1.90
EF	63.02	2.07	3.92	6.00	3.32	9.32
FG	1.69	0.06	0.11	0.16	0.09	0.25
FH	20.93	0.67	1.30	1.97	1.07	3.04
HI	3.49	0.11	0.22	0.33	0.18	0.51
HD	24.81	0.74	1.54	2.29	1.19	3.48
DJ	5.65	0.23	0.35	0.58	0.37	0.95
DK	10.25	0.39	0.64	1.03	0.62	1.65
KL	1.28	0.05	0.08	0.13	0.08	0.21
KM	4.09	0.14	0.25	0.40	0.23	0.63
<b>Total</b>	<b>192.16</b>	<b>6.86</b>	<b>11.97</b>	<b>18.83</b>	<b>10.98</b>	<b>29.81</b>

### *Unit costs by pipeline segment*

Table B.4 presents the derivation of the unit cost by segment.

**Table B.4. Estimated unit cost by pipeline segment**

<b>Pipeline segment</b>	<b>Cost recovery requirement (million Euro)</b>	<b>Gas flow from A (mcmd)</b>	<b>Gas flow from E (mcmd)</b>	<b>Segment flows (mcmd)</b>	<b>Unit cost (Euro/peak day cm)</b>
AB	7.51	30.0		30.0	0.250
BC	0.38	5.0		5.0	0.075
BD	1.90	25.0		25.0	0.076
EF	9.32		50.0	50.0	0.186
FG	0.25		20.0	20.0	0.012
FH	3.04		30.0	30.0	0.101
HI	0.51		10.0	10.0	0.051
HD	3.48		20.0	20.0	0.174
DJ	0.95	11.1	8.9	20.0	0.048
DK	1.65	13.9	11.1	25.0	0.066
KL	0.21	5.6	4.4	10.0	0.021
KM	0.63	8.3	6.7	15.0	0.042

Gas from A and E is mixed from point D onwards pro-rata to the volumes from each stream arriving at D. In deriving the unit cost estimates, it is assumed for simplicity that the total revenue requirement is recovered in capacity tariffs.<sup>19</sup>

<sup>19</sup> It is also assumed that expenditure on system operation activities related to the provision of Third Party Access (TPA) and on specific shipper services is not included in the revenue requirement.

#### 6.1.4 Unit cost matrix

It is now possible to generate a matrix of unit costs and revenues in Table B.5.

**Table B.5. Unit costs and revenues**

	Unit cost (Euro/peak day cm)	Unit cost (Euro/peak day cm)	Revenue recovery (million Euro)	Revenue recovery (million Euro)
	A to B	E to F	A to B	E to F
<b>System access pipeline</b>	0.250	0.186	7.514	9.316
<b>Sub-total</b>				16.830
<b>System entry point</b>	<b>B</b>	<b>F</b>	<b>B</b>	<b>F</b>
<b>System exit point</b>				
<b>C</b>	0.075	0.000	0.376	0.000
<b>G</b>	0.000	0.012	0.000	0.250
<b>I</b>	0.000	0.152	0.000	1.519
<b>J</b>	0.124	0.323	1.373	2.869
<b>L</b>	0.162	0.362	0.902	1.607
<b>M</b>	0.184	0.383	1.531	2.553
<b>Sub-total</b>				12.980
<b>Total</b>				<b>29.810</b>

Table B.5 distinguishes between the unit costs on the system access pipelines and the system entry and exit unit costs. The entries in the system unit cost matrix are derived by summing the segment unit costs along the relevant peak flow path between the entry and exit points. For example, the unit cost from A to J is equal to unit cost (AB + BD + DJ) and that from E to L is equal to unit cost (EF + FH + HD + DK + KL).

Applying the result obtained in Equation 8 (Appendix A above) to the unit cost matrix in Table B.5 generates  $\alpha$  equal to 79.12%. Applying this split between exit and entry tariffs to the row and column averages, respectively, of the unit cost matrix in Table B.5 gives the following initial estimates of entry and exit tariffs and revenues.

*Estimated and adjusted entry and exit tariffs*

**Table B.6. Estimated system entry and exit tariffs and revenues**

	Unit tariffs and revenues (Euro/peak day cm)		Estimated revenue (million Euro)		
	<b>B</b>	<b>F</b>	<b>B</b>	<b>F</b>	
<b>System entry tariffs</b>	<b>0.019</b>	<b>0.043</b>			
<b>System exit tariffs</b>	<b>Entry + Exit</b>				
<b>C</b>	<b>0.030</b>	0.049	0.073	0.243	0.000
<b>G</b>	<b>0.005</b>	0.024	0.048	0.000	0.956
<b>I</b>	<b>0.060</b>	0.079	0.103	0.000	1.030
<b>J</b>	<b>0.177</b>	0.196	0.219	2.173	1.951
<b>L</b>	<b>0.207</b>	0.226	0.250	1.257	1.112
<b>M</b>	<b>0.224</b>	0.243	0.267	2.026	1.780
<b>Total</b>					<b>12.528</b>

The estimated total revenue for the system, at Euro 12.528 million, is less than the required total of Euro 12.980 million in Table B.5. As a result, it is necessary to scale up the estimated entry and exit tariffs to generate the required total.

**Table B.7. Adjusted entry and exit tariffs and revenues**

	Unit tariffs and revenues (Euro/peak day cm)		Estimated revenue (million Euro)		
	<b>A to B</b>	<b>E to F</b>	<b>A to B</b>	<b>E to F</b>	
<b>System access pipelines</b>	<b>0.250</b>	<b>0.186</b>	7.514	9.316	
<b>System entry sub-total</b>					16.830
	<b>B</b>	<b>F</b>	<b>B</b>	<b>F</b>	
<b>System entry tariffs</b>	<b>0.020</b>	<b>0.044</b>			
<b>System exit tariffs</b>	<b>Entry + Exit</b>				
<b>C</b>	<b>0.031</b>	0.050	0.075	0.252	0.000
<b>G</b>	<b>0.005</b>	0.025	0.050	0.000	0.991
<b>I</b>	<b>0.062</b>	0.082	0.107	0.000	1.067
<b>J</b>	<b>0.183</b>	0.203	0.227	2.251	2.021
<b>L</b>	<b>0.215</b>	0.234	0.259	1.302	1.152
<b>M</b>	<b>0.232</b>	0.252	0.277	2.099	1.845
<b>System sub-total</b>					12.980
<b>Total</b>					<b>29.810</b>